



360 EQUI-FLOW™

INSTALLATION INSTRUCTIONS &
OPERATOR'S MANUAL



360 EQUI-FLOW™ INSTALLATION INSTRUCTIONS & OPERATOR'S MANUAL

DISCLAIMER

While all efforts have been made to ensure accuracy, 360 Yield Center® is not responsible for any errors and omissions, and assumes no liability for damages resulting from use of information contained within this document.

360 Yield Center is not responsible or liable for any of the following: incidental or consequential damages, loss of anticipated benefits or profit, stoppage or loss of work, or impairment of data arising of the use or inability to use this system or any of its components. 360 Yield Center will not be held responsible for any repairs or modifications made outside of our facilities, or any damages resulting from improper use or maintenance of this product.

As with all anhydrous ammonia application systems, several factors may affect the accuracy and performance of this system. Because of this, 360 Yield Center cannot guarantee the accuracy, integrity, consistency, or continuity of this system, and cannot guarantee the ability to use the 360 EQUI-FLOW™ system or products used as components of this system in all conditions and circumstances. 360 Yield Center accepts no responsibility for the use of this system or any of its components for other than the stated purpose.

TABLE OF CONTENTS

+ CHAPTER 1: IMPORTANT SAFETY INFORMATION

+ CHAPTER 2: 360 EQUI-FLOW SYSTEM OVERVIEW

+ CHAPTER 3: PARTS DIAGRAM

- 3-1: Mounting Base
- 3-2: Tower Assembly
- 3-3: Pump
- 3-4: Manifold Assembly

+ CHAPTER 4: INSTALLATION

- 4-1: Base Unit Mounting
- 4-2: Splitter/Flow Divider Mounting
- 4-3: Section Mounting
- 4-4: Knife Line Routing
- 4-5: Gauge Tree Mounting
- 4-6: Hydraulic Line Installation
- 4-7: Electrical Harness

+ CHAPTER 5: SYSTEM OPERATION

- 5-1: Monitor/Rate Controller Setup
- 5-2: Meter Cal/Valve Cal
- 5-3: Orifice Selection
- 5-4: Charging the System
- 5-5: Pump Operation
- 5-6: Normal Operation Procedures

+ CHAPTER 6: SERVICE AND MAINTENANCE

- 6-1: Filter Maintenance
- 6-2: Storage

+ CHAPTER 7: TROUBLESHOOTING



CHAPTER 1 IMPORTANT SAFETY INFORMATION

NOTICE

- + Read this manual carefully and thoroughly before installing the 360 EQUI-FLOW system.
- + Review procedures for safe handling and use of anhydrous ammonia (NH_3) with a local NH_3 supplier.
- + If you are not trained to handle anhydrous ammonia, contact a local NH_3 supplier or the appropriate agricultural department for information on training.
- + Please review the operation and safety instructions included with the implement and/or controller.
- + Follow safety information presented within this manual and review operation of the 360 EQUI-FLOW system with a local anhydrous ammonia (NH_3) supplier.
- + Follow all safety labels affixed to the 360 EQUI-FLOW system components. Be sure to keep safety labels in good condition and replace any missing or damaged labels. To obtain replacements for missing or damaged safety labels, contact your 360 EQUI-FLOW distributor.
- + Do not attempt to modify or lengthen any of the system control cables. Proper length cables can be ordered from your 360 EQUI-FLOW distributor.
- + If you require assistance with any portion of the installation or service of the 360 EQUI-FLOW system, contact your 360 Yield Center distributor or call 1-888-512-4890.

I.

CHAPTER 1

IMPORTANT SAFETY INFORMATION (CONTINUED)

! DANGER

+ Anhydrous ammonia (NH_3) is kept under pressure. Anhydrous ammonia can cause severe burning, blindness, or death. **Carefully read and follow all safety instructions and warnings before operating or servicing equipment.** Review safety requirements associated with NH_3 and the 360 EQUI-FLOW manual with a local NH_3 supplier.

+ **Always** wear proper personal protective equipment when working with the 360 EQUI-FLOW system and anhydrous ammonia. Appropriate protective clothing includes, but is not limited to:

- Goggles or face shield
- Protective suit and gloves
- Respirator with approved ammonia (AM/MA) cartridge(s)

+ **DO NOT** allow anyone to operate the 360 EQUI-FLOW system without proper instruction & training.

DECAL AFFIXED TO 360 EQUI-FLOW

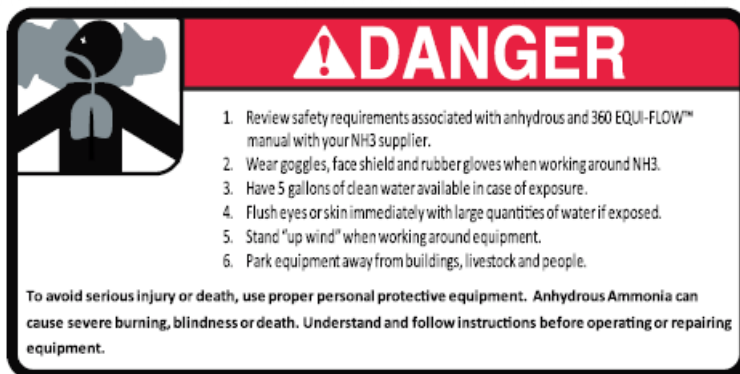

! DANGER

1. Review safety requirements associated with anhydrous and 360 EQUI-FLOW™ manual with your NH_3 supplier.
2. Wear goggles, face shield and rubber gloves when working around NH_3 .
3. Have 5 gallons of clean water available in case of exposure.
4. Flush eyes or skin immediately with large quantities of water if exposed.
5. Stand "up wind" when working around equipment.
6. Park equipment away from buildings, livestock and people.

To avoid serious injury or death, use proper personal protective equipment. Anhydrous Ammonia can cause severe burning, blindness or death. Understand and follow instructions before operating or repairing equipment.

I.

CHAPTER 1

IMPORTANT SAFETY INFORMATION (CONTINUED)

CAUTION

- + Use caution when handling anhydrous ammonia (NH_3) products.
 - Stand up wind when working around anhydrous ammonia (NH_3) and related equipment. Always keep anhydrous ammonia equipment away from buildings, livestock, and other people.
 - Anhydrous ammonia may cause sickness or death. Never work on NH_3 equipment in confined spaces. Seek immediate medical attention if symptoms of illness occur during, or shortly after, use of anhydrous ammonia products.
 - Keep a source of clean water (at least five gallons) readily available while working with anhydrous ammonia. In case of exposure, flush exposed skin or eyes immediately with large quantities of water and seek immediate medical attention.
 - NH_3 can be harmful to the environment if not used properly. Follow all local, state, and federal regulations regarding proper handling of anhydrous ammonia.
- + Always remove the 360 EQUI-FLOW system from service before performing maintenance.
 - Thoroughly bleed all system lines and disconnect nurse tank hose before beginning service or maintenance.
 - Allow a minimum of one (1) hour to fully discharge the system. Verify gauge pressure is at zero before opening the system. Do not loosen any clamps or bolts until system pressure is zero. Opening the towers before complete depressurization may result in serious injury or death.
 - Use extreme caution when opening a previously pressurized system. Anhydrous ammonia may remain in system after opening.

Before performing service or maintenance on the 360 EQUI-FLOW system, read and follow the instructions provided in the 360 EQUI-FLOW Installation Instructions & Operation Manual to properly discharge anhydrous.

DECAL AFFIXED TO 360 EQUI-FLOW

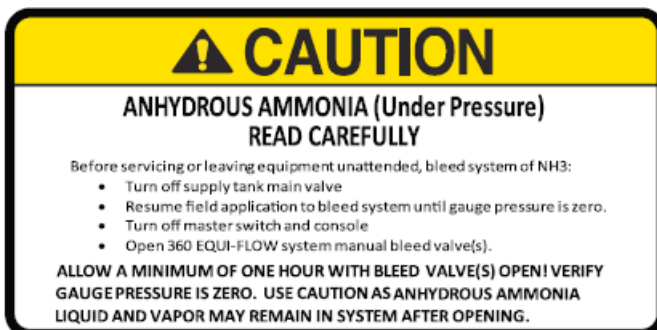

I.

CHAPTER 1

IMPORTANT SAFETY INFORMATION (CONTINUED)

DISCHARGING THE 360 EQUI-FLOW SYSTEM

PERSONAL PROTECTIVE EQUIPMENT REQUIRED:

- + Respirator*
- + Face Shield/ Goggles*
- + Protective Suit*
- + Gloves*
- + Long Pants and Long Sleeves*

* Must be rated for anhydrous ammonia (NH₃) use.

The 360 EQUI-FLOW system must be discharged of all anhydrous ammonia and the system must be completely deactivated before transporting the implement.

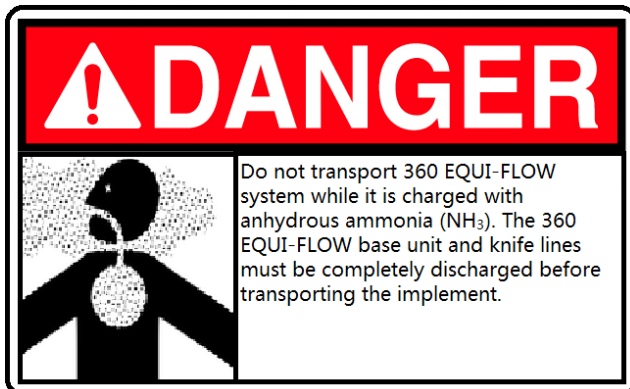

Please follow the outlined procedure below on how to properly discharge anhydrous ammonia (NH₃) from the 360 EQUI-FLOW system prior to transport, service, or maintenance.

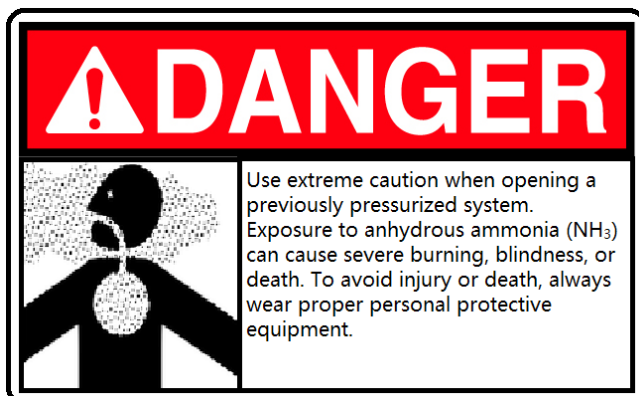

I.

CHAPTER 1 IMPORTANT SAFETY INFORMATION (CONTINUED)

DISCHARGING THE 360 EQUI-FLOW SYSTEM (CONTINUED)

DISCHARGING PRECAUTIONS:

- + Review safety requirements associated with anhydrous ammonia (NH_3) and the 360 EQUI-FLOW manual with your NH_3 supplier.
- + Wear goggles, face shield, and rubber gloves approved for anhydrous ammonia use when working around NH_3 .
- + Have 5 gallons of clean water available in case of exposure.
- + Flush eyes or skin immediately with large quantities of water if exposed.
- + Stand up wind when working around equipment.
- + Park equipment away from buildings, livestock, and people.

DISCHARGING STEPS:

FIGURES 1 AND 2

STEP 1 Turn off supply tank main valve. Bleed nurse tank supply hoses.

FIGURE 3

STEP 2 Resume field application to bleed system until gauge pressure is zero. Disengage tractor SCV switch to pump.

STEP 3 Turn off master switch and console.

CONTINUED ON NEXT PAGE...

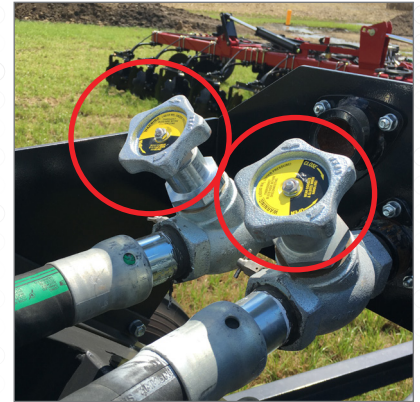

FIGURE 1



FIGURE 2

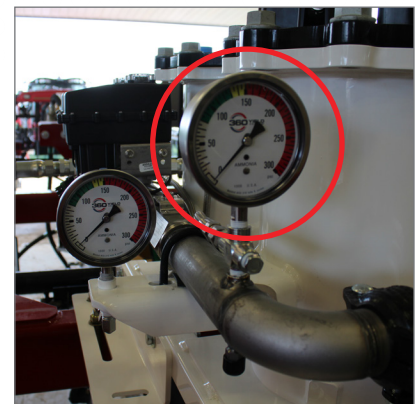

FIGURE 3

I.

CHAPTER 1 IMPORTANT SAFETY INFORMATION (CONTINUED)

DISCHARGING THE 360 EQUI-FLOW SYSTEM (CONTINUED)

DISCHARGING STEPS (CONTINUED):

FIGURES 4 AND 5

STEP 4 First, open bottom (FIGURE 4) and then top (FIGURE 5) manual bleed valves on the 360 EQUI-FLOW base unit. It is best practice to open the bleeder valve located at the bottom of the tower to drain out any remaining liquid NH_3 before opening the top bleeder valve.

STEP 5 Allow a **minimum of one hour** with bleed valves open! Verify gauge pressure is zero. Use caution as anhydrous ammonia liquid and vapor may remain in the system after opening.



FIGURE 4



FIGURE 5



CHAPTER 2 360 EQUI-FLOW SYSTEM OVERVIEW

The 360 EQUI-FLOW with LIQUIMATIC® technology is an anhydrous ammonia application system designed to deliver equal distribution of anhydrous ammonia to each row on an applicator. The 360 EQUI-FLOW system condenses anhydrous ammonia (NH₃) as it enters from the nurse tank and delivers liquid anhydrous ammonia to the manifold(s) on the applicator where it is orificed to deliver equal amounts of anhydrous ammonia to the knife lines and provide consistent row-to-row accuracy.

TRADITIONAL SYSTEMS

Traditional anhydrous ammonia application systems attempt to cool the anhydrous ammonia under its boiling temperature of -28°F [-33°C] through the use of heat exchangers and condensers. This process can lead to inadequate cooling of the anhydrous ammonia and does not limit the creation of vapors, specifically as the pressure drops through the system, which leads to poor row-to-row delivery of anhydrous ammonia.

360 EQUI-FLOW

360 EQUI-FLOW filters the anhydrous ammonia and separates the liquid from the vapor in its proprietary LIQUIMATIC® dual tower system. Anhydrous ammonia is then condensed into a pure liquid form by pressurizing the product with a centrifugal pump throughout the remainder of the system above nurse tank pressure. Product is then more accurately metered as liquid through the flowmeter before being divided equally to all rows.

COLD TEMPERATURE OPERATION

Traditional systems on the market rely on the pressure drop from the nurse tank to the application point (knives, boots, etc) to deliver anhydrous ammonia. This can become a challenge in colder temperatures when nurse tank pressures are low and flow rates become a concern. 360 EQUI-FLOW only relies on the flow of anhydrous ammonia from the nurse tank into the towers on the system, from there it is pressurized and delivered to the rows, eliminating slow application concerns in colder operating temperatures.

II.

CHAPTER 2 360 EQUI-FLOW SYSTEM OVERVIEW (CONTINUED)

STANDARD CONFIGURATION

360 EQUI-FLOW is available in one pre-assembled base configuration which includes the tower system, pump, flowmeter, on/off valve, and control valve capable of applying up to 70 gallons per minute [265 liters per minute] even in colder temperatures.

360 EQUI-FLOW BASE SYSTEM	PART NUMBER
360 EQUI-FLOW BASE UNIT	472000
EQUI-FLOW MOUNTING BASE ASSEMBLY	472100
TOWER ASSEMBLY	472200
EQUI-FLOW PUMP ASSEMBLY	472300
BASE UNIT MANIFOLD ASSEMBLY	472400
BASE SYSTEM WIRING HARNESS	470500

SECTION CONFIGURATION

The 360 EQUI-FLOW system can be set up in multiple section options:

- FIGURE 6** A splitter can be mounted to the base unit supplying multiple flow dividers as sections.
- FIGURE 7** A T-fitting can be mounted to the base unit to supply two flow dividers as sections.
- FIGURE 8** A flow divider can be mounted directly to the base unit as a single section system.

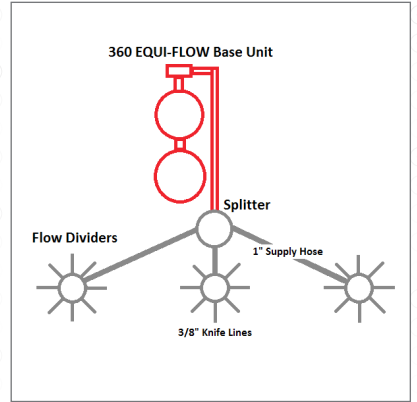

FIGURE 6

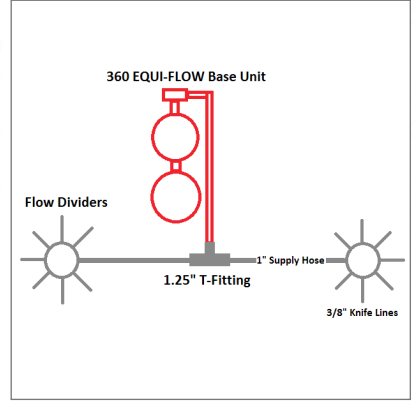

FIGURE 7

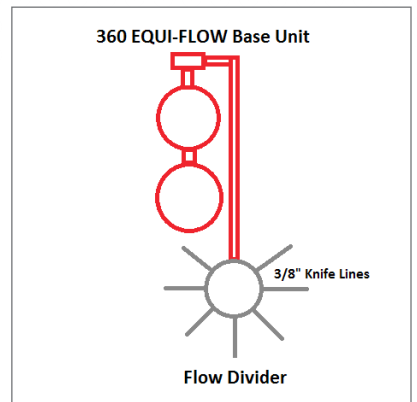
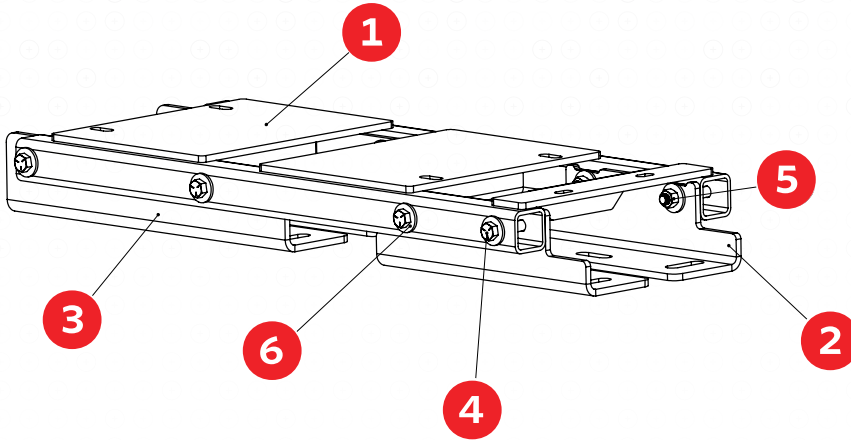

FIGURE 8

3-1: MOUNTING BASE



ITEM NO.	PART NUMBER	DESCRIPTION	QTY
1	472101	EQUI-FLOW BASE	1
2	472106	EQUI-FLOW BASE - 13-3/4" FRONT BRACKET	2
3	472107	EQUI-FLOW BASE - 18-1/4" REAR BRACKET	2
4	201100	1/2" X 3-1/4" BOLT	8
5	207050	1/2" LOCK NUT	8
6	207051	1/2" WASHER	16
N/P	416234	4"X6" U-BOLT KIT	4

3-2: TOWER ASSEMBLY

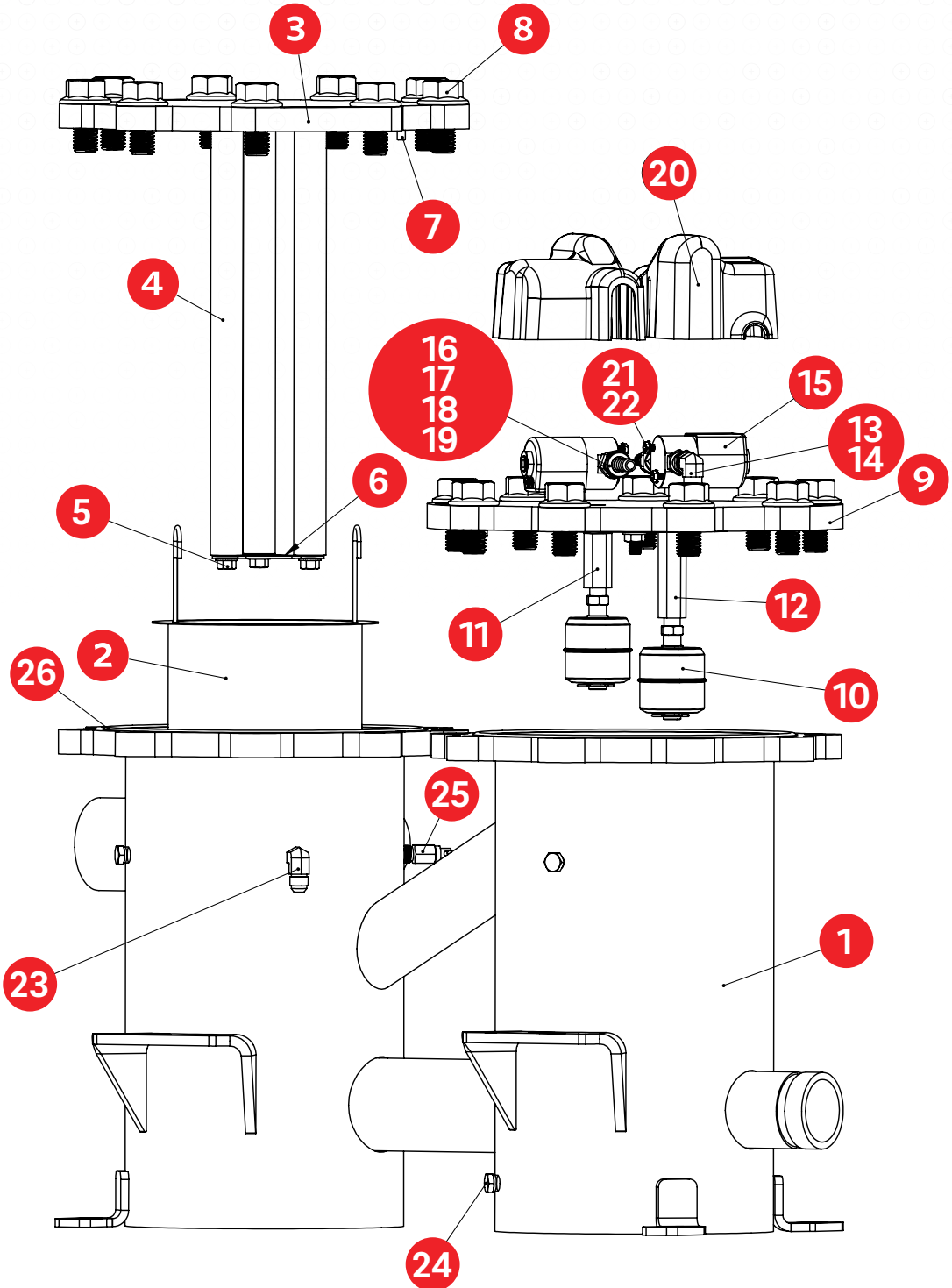

III.

CHAPTER 3 PARTS DIAGRAMS (CONTINUED)

3-2: TOWER ASSEMBLY (CONTINUED)

ITEM NO.	PART NUMBER	DESCRIPTION	QTY
1	472201	EQUI-FLOW TOWERS	1
2	472220	FILTER STRAINER BASKET	1
3	472231	FILTER TOWER CAP	1
4	472221	FILTER STRAINER MAGNET	3
5	270102	5/16" X 1/2" BOLT	3
6	472232	MAGNET RETAINER PLATE	1
7	270101	SS DOWEL PIN	2
8	270114	3/4" X 1 1/2" FLANGE BOLT	18
9	472241	SEPARATION TOWER CAP	1
10	472243	LIQUID LEVEL FLOAT SENSOR	2
11	472244	1/4" NPT, SHORT PIPE COUPLER	1
12	472245	1/4" NPT, LONG PIPE COUPLER	1
13	472246	LONG ELBOW, 1/4" MNPT X 3/8" MJIC	2
14	470240	3/8" FJIC X 1/4" MNPT	2
15	472247	SOLENOID VALVE	2
16	470242	1/4" MNPT ORIFICE BODY	2
17	418225	SS 125 ORIFICE PLATE	2
18	470245	ORIFICE BODY NUT	2
19	472248	3/8" HOSE BARB	2
20	472249	SOLENOID VALVE CAP	2
21	270115	10-32 X 1/2" SCREW	4
22	270116	#10 EXTERNAL TOOTH WASHER	1
23	470250	ELBOW, 3/8" MJIC X 1/4" MNPT	3
24	470251	1/4" MNPT PLUG	1
25	470252	PRESSURE BLEED OFF VALVE	2
26	472251	O-RING GASKET	3
N/P	270113	FILTER TOWER STUD	1
N/P	472242	SPLASH PLATE	1
N/P	470238	SEPARATION TOWER STUD	1
N/P	207059	3/8" STUD HEX NUT	1
N/P	470237	1/4" NPT MXF COUPLER	1
N/P	472252	NEEDLE PRESSURE BLEED OFF VALVE	1
N/P	473032	3/8" HOSE BARB X 1/4" MNPT	1
N/P	270106	1/2" X 1 1/2" BOLT	4
N/P	207050	1/2" LOCK NUT	4
N/P	207051	1/2" WASHER	8

III.

CHAPTER 3 PARTS DIAGRAMS (CONTINUED)

3-3: PUMP

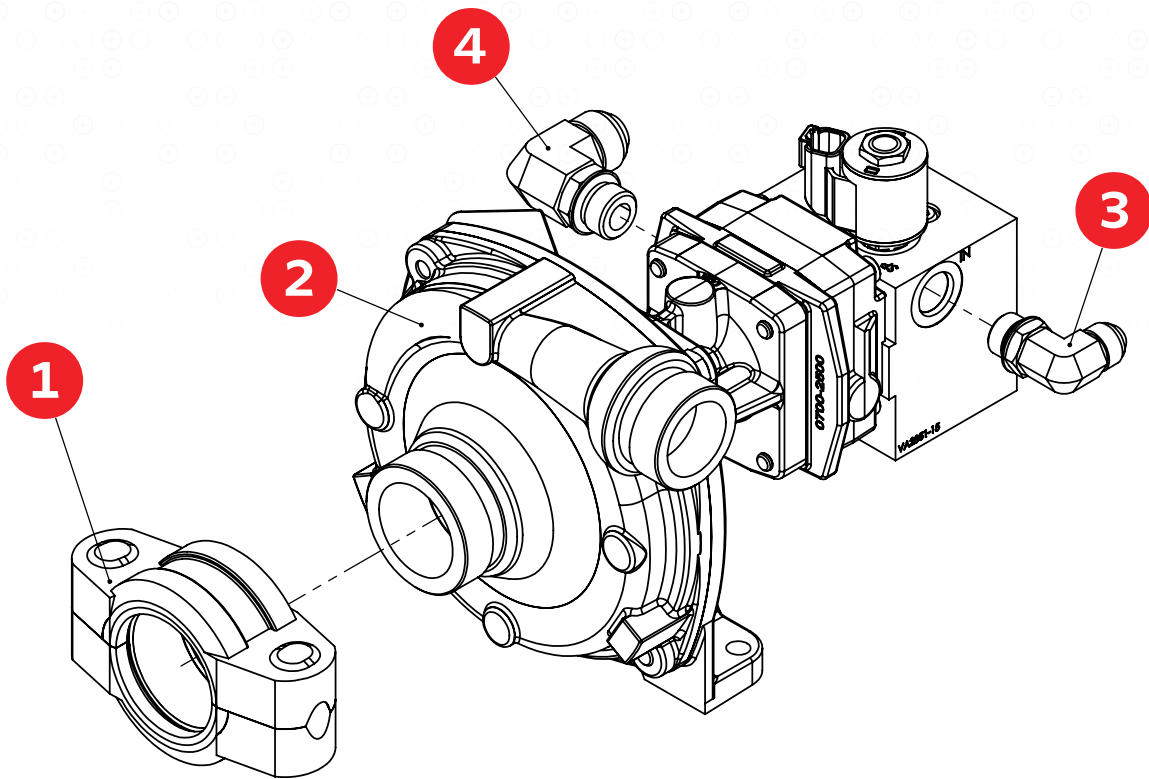

ITEM NO.	PART NUMBER	DESCRIPTION	QTY
1	472301	2" PIPE CLAMPS, BOLTS, GASKET	1
2	472303	PUMP, MOTOR, VALVE	1
3	470316	8-8 ORB ELBOW	1
4	470317	10-8 ORB ELBOW 3/8" X 1-1/2" BOLT	1
N/P	270107	3/8" X 1-1/2" BOLT	2
N/P	270108	3/8" LOCK NUT	2
N/P	270109	3/8" WASHER	2

CHAPTER 3 PARTS DIAGRAMS (CONTINUED)

3-4: MANIFOLD ASSEMBLY

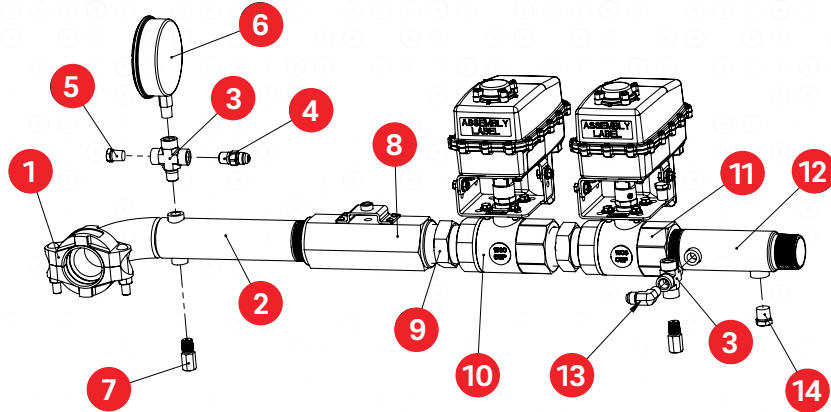

ITEM NO.	PART NUMBER	DESCRIPTION	QTY
1	472401	1 1/2" CLAMPS/BOLTS/GASKET	1
2	472402	1 1/2", PIPE CLAMP X MNPT	1
3	472403	MNPT, FNPT (X3) CROSS	2
4	470239	MJIC X MNPT ADAPTER	1
5	470251	1/4" NPT PLUG (OPTIONAL PRESSURE TRANSDUCER SPOT)	2
6	470310	300 PSI PRESSURE GAUGE	2
7	470311	PRESSURE RELIEF VALVE	2
8	470403	FLOW METER	1
9	470405	1 1/2" PIPE NIPPLE	2
10	470407	CONTROL VALVE (RED)	1
11	470406	MASTER VALVE (YELLOW)	1
12	472404	1 1/2" X 1 1/4" MNPT	1
13	470250	ELBOW, 3/8" MJIC X 1/4" MNPT	1
14	470416	3/8" MNPT PLUG	1
N/P	472308	SS BRAIDED HOSE, 1/4" X 18"	1
N/P	472309	SS BRAIDED HOSE, 1/4" X 22"	1
N/P	472405	GAUGE MOUNTING MANIFOLD BRACKET	1
N/P	472406	MANIFOLD BRACKET	1
N/P	270110	7/16" X 1 1/2" BOLT	4
N/P	207046	7/16" LOCK NUT	4
N/P	207047	7/16" WASHER	4
N/P	201021	2" X 3/8" U-BOLT	1
N/P	201023	2 7/16" X 3/8" U-BOLT	1
N/P	270108	3/8" LOCK NUT	4
N/P	270109	3/8" WAHSER	4
N/P	270117	FIR TREE ZIP TIE	2
N/P	470403	FLOW SENSOR	1

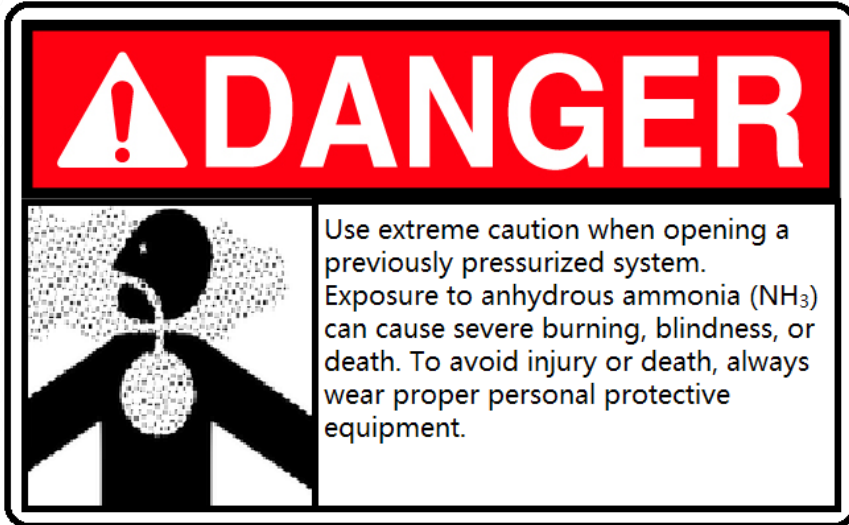

Use this section as a guide for installation of your 360 EQUI-FLOW system onto a standard toolbar.

IV.

CHAPTER 4 INSTALLATION (CONTINUED)

4-1: BASE UNIT MOUNTING

The 360 EQUI-FLOW mounting base is intended to be modular and be adjusted to mount to a variety of toolbar brands and designs. The front and rear brackets can be turned 180 degrees and can also be oriented to the inside or outside of the mounting base. The brackets can also be staggered to avoid permanent hardware that might otherwise interfere with installation.

Several mounting orientations are shown in Figures 9-12 to the right.

The base unit can be mounted so that the pump is facing the front of the implement or it can be turned 90 degrees so that the manifold is towards the front of the implement.

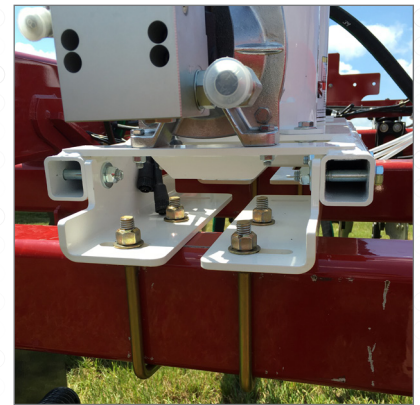

FIGURE 9 - CASE IH 930



FIGURE 10 - JOHN DEERE 2410C



FIGURE 11 - JOHN DEERE 2510H



FIGURE 12 - CASE IH 930

IV.

CHAPTER 4 INSTALLATION (CONTINUED)

4-1: BASE UNIT MOUNTING

STEP 1: POSITION 360 EQUI-FLOW BASE UNIT

FIGURE 13

STEP 1A Insert minimum 1,000lb lifting strap through loop in the lid of the tower closest to the pump. Using a fork lift, slowly and carefully lift the base unit up.



FIGURE 13

FIGURE 14

STEP 1B Position the mounting brackets to the proper orientation to mount your toolbar. Position the base unit over the toolbar and slowly lower into the mounting location.

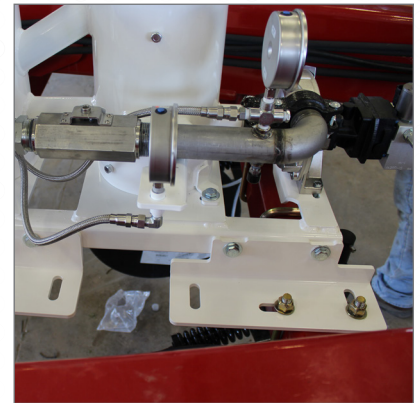

FIGURE 14

FIGURE 15

STEP 1C Install included 4" x 6" u-bolts (416234) upwards through mounting brackets. Lubricate threads on u-bolts and install included washers and nuts (416234). Torque nuts down to 170ft/lbs.



FIGURE 15

NOTE: U-bolt threads must be lubricated before installing and tightening nuts!

STEP 2: FOLD TOOLBAR

FIGURE 16

STEP 2A Slowly fold toolbar into transport position. Ensure that all toolbar wings, coulters, knives, brackets, etc. will not touch the 360 EQUI-FLOW base unit. The base unit must have adequate clearance from all toolbar structures.



FIGURE 16

IV.

CHAPTER 4 INSTALLATION (CONTINUED)

4-2: SPLITTER/FLOW DIVIDER MOUNTING

Refer to the proper section mounting guide for which your system is configured.

FIGURE 17

4-2A: MULTIPLE SECTION WITH SPLITTER

STEP 1: MOUNT SPLITTER

Components used in this section:

4 PORT SPLITTER CONNECTION KIT (470600)

PART NUMBER	DESCRIPTION	QUANTITY
470624	4 PORT SPLITTER	1
472601	1-1/4" 90 DEGREE ELBOW	1
470415	1-1/4" NIPPLE - MALE PIPE	1

6 PORT SPLITTER CONNECTION KIT (470601)

PART NUMBER	DESCRIPTION	QUANTITY
470626	6 PORT SPLITTER	1
472601	1-1/4" 90 DEGREE ELBOW	1
470415	1-1/4" NIPPLE - MALE PIPE	1

FIGURE 18

- STEP 1A** Prepare male fittings by wrapping with stainless steel thread tape or appropriate thread sealant.
- STEP 1B** Install 1-1/4" 90 degree elbow (472601) (1, FIGURE 18) to the end of the EQUI-FLOW manifold.
- STEP 1C** Install 1-1/4" nipple (470415) (2, FIGURE 18) into 1-1/4" elbow installed in Step 1B.
- STEP 1D** Install 4 or 6 port splitter (470624, 470626) (3, Figure 18) onto nipple.
- STEP 1E** Prepare 1" x 1" male to female swivel fittings* (470651) (1, Figure 19) by wrapping with stainless steel thread tape or appropriate thread sealant. Install swivel fittings into splitter.
 - * 1" x 1" swivel fittings are available in 90 degree, 45 degree, and straight.
 - * Thread tape is not required in the female junction of any swivel fittings.

STEP 1F Install 1" pipe plug (470645) into any unused ports.

SKIP TO SECTION MOUNTING PAGE 23

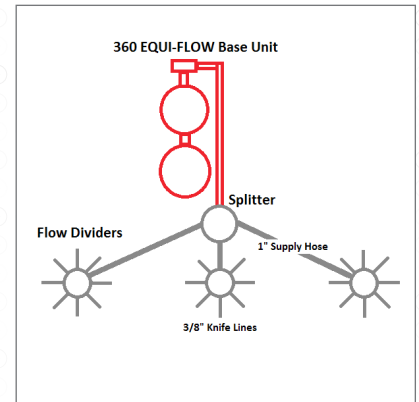

FIGURE 17

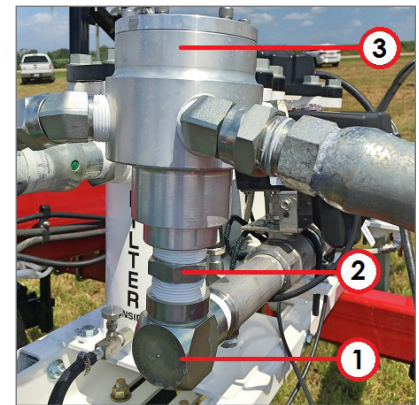

FIGURE 18

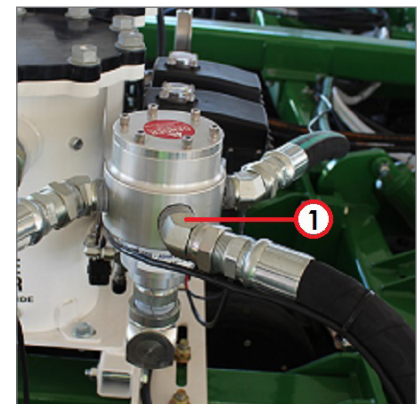

FIGURE 19

IV.

CHAPTER 4 INSTALLATION (CONTINUED)

4-2: SPLITTER/FLOW DIVIDER MOUNTING (CONTINUED)

FIGURE 20

4-2B: 2 SECTION WITH T-FITTING OFF OF BASE UNIT

STEP 1: MOUNT T-FITTING

Components used in this section:

2 SECTION TEE SPLITTING KIT (470602)

PART NUMBER	DESCRIPTION	QUANTITY
470637	FEMALE T - 1-1/4" X 1-1/4" X 1-1/4"	1
470638	REDUCER BUSHING - 1-1/4" x 1"	2
470651	1"x1" MALE TO FEMALE SWIVEL	2

STEP 1A Prepare male fittings by wrapping with stainless steel thread tape or appropriate thread sealant.

FIGURE 21

STEP 1B Install female T-Fitting (470637) (1, Figure 21) to the end of the EQUI-FLOW manifold.

STEP 1C Install reducer bushings (470638) (2, Figure 21) into the opposing ends of the female T-fitting.

STEP 1D Prepare 1" x 1" male to female swivel fittings* (470651) (3, Figure 21) by wrapping with stainless steel thread tape or appropriate thread sealant. Install swivel fittings into splitter.

- * 1" x 1" swivel fittings are available in 90 degree, 45 degree, and straight.
- * Thread tape is not required in the female junction of any swivel fittings.

SKIP TO SECTION MOUNTING PAGE 23

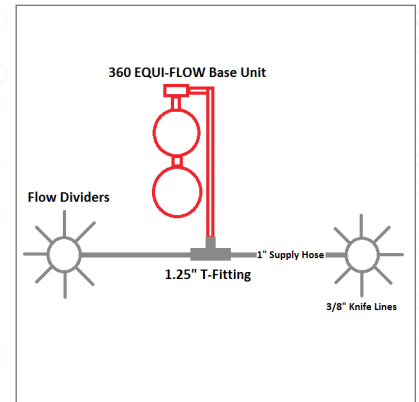

FIGURE 20

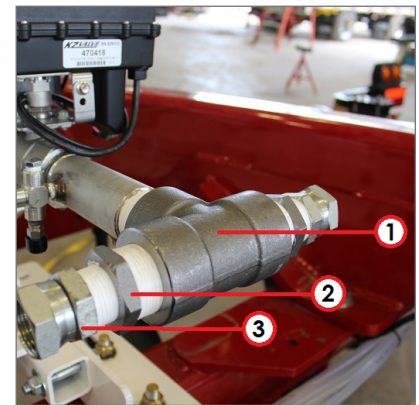

FIGURE 21

IV.

CHAPTER 4 INSTALLATION (CONTINUED)

4-2: SPLITTER/FLOW DIVIDER MOUNTING (CONTINUED)

FIGURE 22

4-2C: FLOW DIVIDER DIRECT TO BASE UNIT

STEP 1: MOUNT FLOW DIVIDER

Components used in this section:

18 PORT FLOW DIVIDER KIT (470611)

PART NUMBER	DESCRIPTION	QUANTITY
470618	18 PORT FLOW DIVIDER	1
472602	1-1/4" X 1" 90 DEGREE ELBOW	1
470650	1" NIPPLE - MALE PIPE	1

STEP 1A Prepare male fittings by wrapping with stainless steel thread tape or appropriate thread sealant.

FIGURE 23

STEP 1B Install 1-1/4" X 1" 90 degree elbow (472602) (1, FIGURE 23) to end of EQUI-FLOW manifold.

STEP 1C Install 1" nipple (470650) (2, FIGURE 23) into 1" female end of 90 degree elbow installed in Step 1B.

STEP 1D Install 18 port flow divider (470618) (3, FIGURE 23).

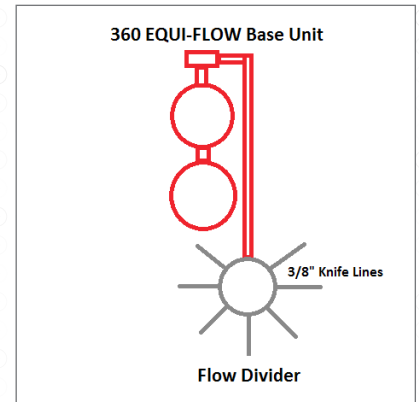

FIGURE 22

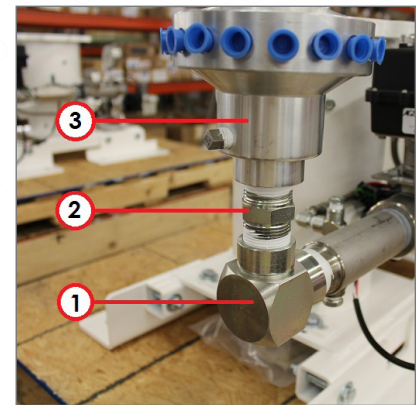

FIGURE 23

IV.

CHAPTER 4 INSTALLATION (CONTINUED)

4-3: SECTION MOUNTING

STEP 1: ASSEMBLE SECTION ACCESSORIES KIT

Components used in this section:

12" MOUNTING BRACKET SECTION ACCESSORIES KIT (470640)

PART NUMBER	DESCRIPTION	QUANTITY
470646	12" SECTION MANIFOLD BRACKET	1
470642	1" KZ VALVE	1
470651	SWIVEL - 1" X 1" MALE TO FEMALE	1
416234	4" X 6" U-BOLT KIT	1
470649	1" X 1" 90 DEGREE ELBOW	1
470650	1" NIPPLE - MALE PIPE	1
470251	1/4" PIPE PLUG	6

OR 18" MOUNTING BRACKET SECTION ACCESSORIES KIT (470641)

PART NUMBER	DESCRIPTION	QUANTITY
470647	18" SECTION MANIFOLD BRACKET	1
470642	1" KZ VALVE	1
470651	SWIVEL - 1" X 1" MALE TO FEMALE	1
416234	4" X 6" U-BOLT KIT	1
470649	1" X 1" 90 DEGREE ELBOW	1
470650	1" NIPPLE - MALE PIPE	1
470251	1/4" PIPE PLUG	6

OPTIONAL: SECTION STRAINER KIT (470655)

PART NUMBER	DESCRIPTION	QUANTITY
470656	1" STRAINER	1
470650	1" NIPPLE - MALE PIPE	1

SECTION ASSEMBLY WITHOUT SECTION STRAINERS

- STEP 1A** Prepare male fittings by wrapping with stainless steel thread tape or appropriate thread sealant.
- STEP 1B** Secure section manifold bracket (470646 or 470647) in vice.
- FIGURE 24**
- STEP 1C** Install KZ valve (470642) (1, FIGURE 24) to section manifold bracket. The arrow indicating flow direction will be pointed towards the bracket!
- STEP 1D** Install 1" x 1" 90 degree elbow (470649) (2, FIGURE 24) on opposite side of section manifold bracket.
- STEP 1E** Install 1" nipple (470650) (3, FIGURE 24) into 90 degree elbow.
- STEP 1F** Install 6, 13, or 18 port flow divider onto 1" nipple.
- STEP 1G** Install 1" swivel (470651) (4, FIGURE 24) into KZ valve.

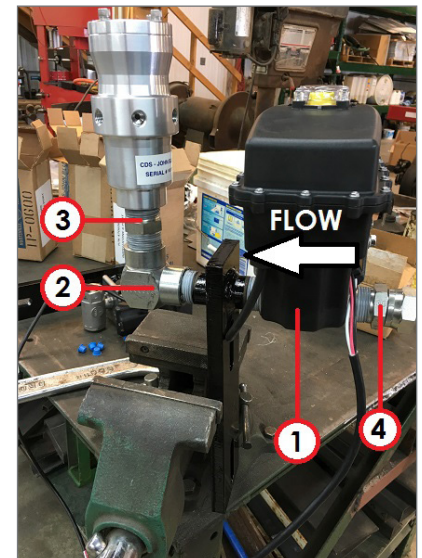

FIGURE 24

IV.

CHAPTER 4 INSTALLATION (CONTINUED)

4-3: SECTION MOUNTING (CONTINUED)

STEP 1: ASSEMBLE SECTION ACCESSORIES KIT (CONTINUED)

SECTION ASSEMBLY WITH SECTION STRAINERS

STEP 1A Secure section manifold bracket (470646 or 470647) in vice.

FIGURE 25

STEP 1B Install 1" section strainer (470656) (1, FIGURE 25) onto section manifold bracket. The arrow indicating flow direction will be pointed towards the bracket!

STEP 1C Install 1" KZ valve (470642) (2, FIGURE 25) onto opposite side of section manifold bracket. The arrow indicating flow direction will be pointed away from the bracket!

STEP 1D Install 1" nipple (470650) (3, FIGURE 25) into KZ valve.

STEP 1E Install 1" x 1" 90 degree elbow (470649) (4, FIGURE 25) onto nipple.

STEP 1F Install 1" nipple (470642) (3, FIGURE 25) into 90 degree elbow.

STEP 1G Install 6, 13, or 18 port flow divider onto 1" nipple.

STEP 1H Install 1" swivel (470651) (5, FIGURE 25) into strainer.

STEP 2: MOUNT SECTION TO TOOLBAR

STEP 2A Identify safe location to mount sections.

STEP 2B Ensure that the toolbar folds will not interfere with section.

STEP 2C Use 4"x6" u-bolt (416234) to mount bracket and section assembly to toolbar.

NOTE: Lubricate u-bolt threads before installing washers and nuts!

STEP 3: ROUTE 1" SUPPLY HOSES

FIGURE 26

STEP 3A Install 1" supply hoses from the splitter or T-fitting to each section.

STEP 3B Use 1" swivel fittings to tighten 1" supply hose.

NOTE: Thread tape not required.

STEP 3C Loop and secure any slack that may be left in the line.

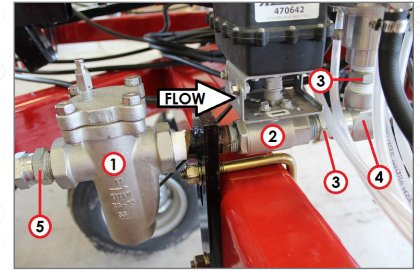

FIGURE 25



FIGURE 26

IV.

CHAPTER 4 INSTALLATION (CONTINUED)

4-4: KNIFE LINE ROUTING

STEP 1: INSTALL FLOW DIVIDER FITTINGS

Components used in this section:

FLOW DIVIDER ACCESSORY KIT - NO GAUGE TREE - 1/ROW (470660)

PART NUMBER	DESCRIPTION	QUANTITY
470242	1/4" ADAPTER	1
470245	ORIFICE BODY NUT	1
472248	3/8" BARBED HOSE SHANK	1
207010	HOSE CLAMP	2

LOW DIVIDER ACCESSORY KIT - GAUGE TREE - 1/ROW (470665)

PART NUMBER	DESCRIPTION	QUANTITY
470242	1/4" ADAPTER	1
470663	3/8" AND 1/4" BARBED FITTING	1
207010	HOSE CLAMP	2

FIGURES 27 AND 28

STEP 1A Prepare 1/4" Adapters (470242) (1, FIGURES 27 & 28) by wrapping 1/4" thread with stainless steel thread tape or appropriate thread sealant.

NOTE: Orifice side does not require thread tape.

STEP 1B Install 1/4" adapters (470242) (1, FIGURES 27 & 28) into flow dividers.

STEP 1C Install appropriate sized orifice* into orifice body nut or airway cap.

* Orifice chart on page 34

STEP 1D Install orifice body nut (470245) and 3/8" barbed hose shank (472248) (2 & 3, FIGURE 27) onto 1/4" adapters. If using gauge tree install barbed hose fitting adapter (470663) (2, FIGURE 28) onto 1/4" adapters.

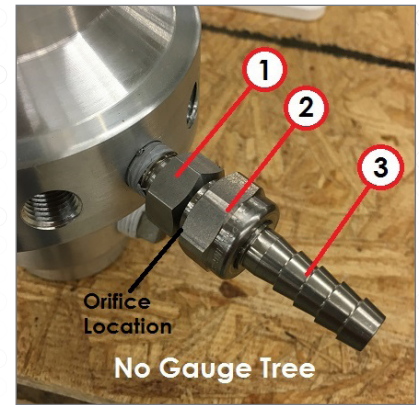

FIGURE 27

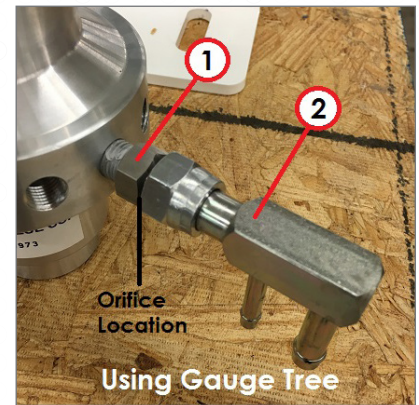

FIGURE 28

IV.

CHAPTER 4 INSTALLATION (CONTINUED)

4-4: KNIFE LINE ROUTING (CONTINUED)

STEP 2: INSTALL KNIFE LINES

- + It is recommended that all knife lines be kept the same length to maintain the most accurate application of anhydrous ammonia.
- + It is a good practice to number your knife lines as shown in *FIGURE 29* to the right.

FOLLOWING STEPS USING 3/8" EPDM BLACK FERTILIZER HOSE

- STEP 2A** Route longest distance knife from flow divider.
- STEP 2B** Cut longest length hose and use as a guide to cut the remainder of hoses.
- STEP 2C** Route hose from knife to flow divider outer hose barbs.

NOTE: Be sure to leave enough slack to accommodate folds in the toolbar.

- STEP 2D** Install hose clamps on flow divider and knife ends of the hose.

FIGURES 29 AND 30 SHOW HOSES INSTALLED WITH GAUGE TREE HOSES.



FIGURE 29



FIGURE 30

IV.

CHAPTER 4 INSTALLATION (CONTINUED)

4-5: GAUGE TREE MOUNTING

The following section is only for systems configured with an optional gauge tree.

STEP 1: MOUNTING GAUGE TREE

STEP 1A Prepare gauge threads and 1/4" hose barb by wrapping with stainless steel thread tape or appropriate thread sealant.

FIGURE 31

STEP 1B Install gauges (471531) (1, FIGURE 31) and 1/4" hose barbs (471532) (3, FIGURE 31) onto 4 or 6 row gauge mount plate (471504 or 471506) (2, FIGURE 31)

STEP 1C Mount assembled gauge mount plate to gauge tree stand (471500) (4, FIGURE 31)

STEP 1D Mount gauge tree to toolbar in a cab-visible location that is free of interference of tractor tires and toolbar folds.

NOTE: The gauge tree bottom plate can be mounted with standard bolts or with 4"x 6" u-bolts included.

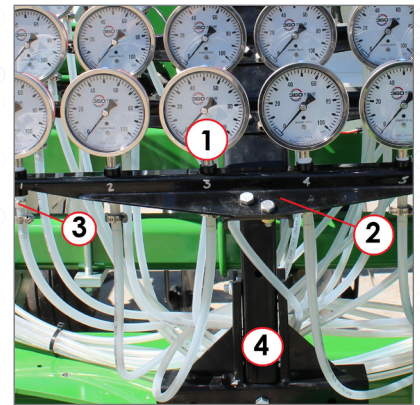

FIGURE 31

STEP 2: ROUTING GAUGE TREE LINES

+ It is a good practice to number your knife lines as shown in FIGURE 29 on page 26.

FOLLOWING STEPS USING 1/4" EVA TUBING

STEP 2A Route the longest distance hose from each flow divider.

STEP 2B Ensure there is adequate slack to accommodate folding of the toolbar.

STEP 2C Use cut hoses for each flow divider as a guide to cut remainder of hoses for each flow divider.

STEP 2D Route hoses from flow divider inner hose barbs to gauge tree.

STEP 2E Install 1/4" hose clamps on flow divider and gauge tree ends.

STEP 2F For a cleaner installation, group all common flow divider gauge tree hoses with cable ties.

IV.

CHAPTER 4 INSTALLATION (CONTINUED)

4-6: HYDRAULIC LINE INSTALLATION

STEP 1: ROUTE HYDRAULIC LINES

STEP 1A Route hydraulic lines from base unit to tractor.

NOTE: Run hydraulic lines with all other toolbar hydraulic lines.

FIGURE 32

STEP 1B 1/2" (1, FIGURE 32) hydraulic line will go to supply.

STEP 1C 3/4" (2, FIGURE 32) hydraulic line will go to return.

NOTE: Return can be routed through SCV or case drain.

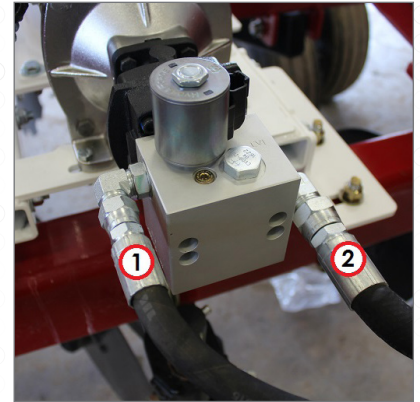

FIGURE 32

IV.

CHAPTER 4 INSTALLATION (CONTINUED)

4-7: ELECTRICAL HARNESS

FIGURE 33
RAVEN HARNESS/ RATE CONTROLLER

To connect the 360 EQUI-FLOW system to a Raven rate controller, you will utilize a Raven electrical harness and adapters listed below. The adapters will allow you to connect the Raven harness to the 360 EQUI-FLOW base unit. The adapters include:

1. Master Valve Adapter (470523)
2. Control Valve Adapter (470524)
3. Flow Meter Adapter (470525)

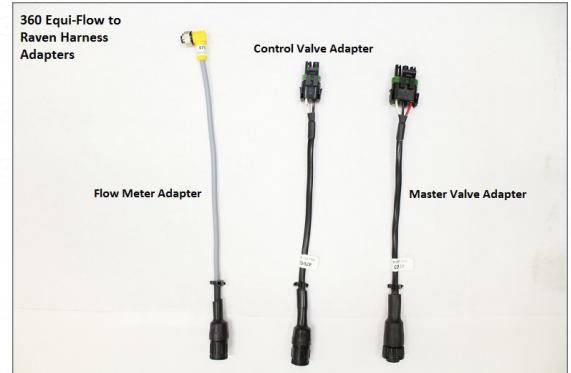

FIGURE 33

FIGURE 34
JOHN DEERE RATE CONTROLLER

To connect the 360 EQUI-FLOW system to a John Deere rate controller, you will utilize a single section, 4 section, or 6 section electrical harness depending on the number of controllable sections being used on the system. Plugs on the harness listed below will plug directly into the labeled harness on the 360 EQUI-FLOW base unit.

1. Single Section Harness (470503)
2. 4 Section Harness (470508)
3. 6 Section Harness (470509)

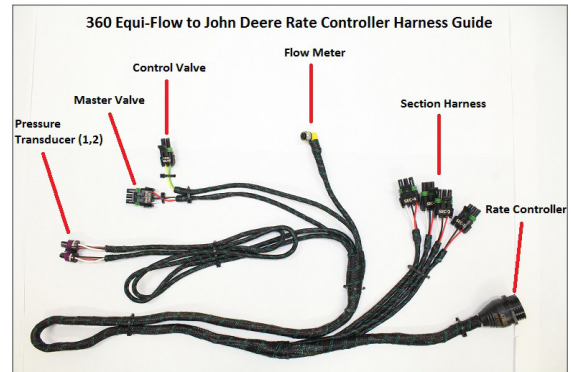

FIGURE 34

IV.

CHAPTER 4 INSTALLATION (CONTINUED)

4-7: ELECTRICAL HARNESS (CONTINUED)

FIGURES 35 AND 36

PRESSURE TRANSDUCERS

Pressure transducers (471601) are available for the gauges on the 360 EQUI-FLOW base unit so that the pressures can be visualized on a rate controller monitor. The pressure transducers will be mounted by removing the plugs from the front and rear gauge lines and installing them into the open port as shown in *FIGURES 35 & 36*.

FIGURE 37

SECTION HARNESSES

Sections will be connected to the rate controller using 20, 30, or 40ft Section Extension Harnesses. Connect them starting with Section 1 to the left (as sitting in the cab) with the remaining sections following to the right.

1. 20ft Section Extension Harness (470520)
2. 30ft Section Extension Harness (470521)
3. 40ft Section Extension Harness (470522)



FIGURE 35



FIGURE 36



FIGURE 37

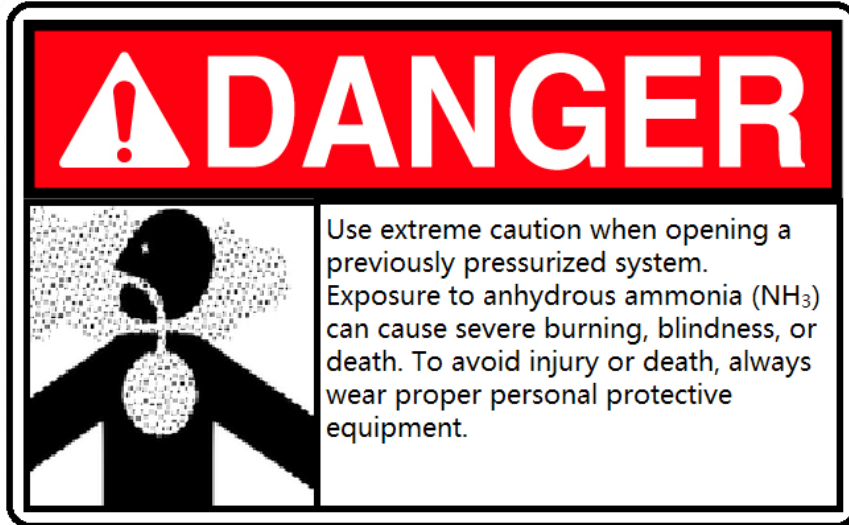

- + Anhydrous Ammonia (NH_3) is kept under pressure. Anhydrous ammonia can cause severe burning, blindness, or death. Carefully read and follow all safety instructions and warnings before operating or servicing equipment. Review safety requirements associated with NH_3 and the 360 EQUI-FLOW manual with a local NH_3 supplier.
- + Always wear proper personal protective equipment when working with the 360 EQUI-FLOW system and anhydrous ammonia. Appropriate protective clothing includes, but is not limited to:
 - Goggles or face shield
 - Protective suit and gloves
 - Respirator with approved ammonia (AM/MA) cartridge(s)
- + **DO NOT** allow anyone to operate the 360 EQUI-FLOW system without proper instruction and training.



CHAPTER 5 SYSTEM OPERATION (CONTINUED)

5-1: MONITOR/RATE CONTROLLER SET-UP

- STEP 1** Before charging the system, it is important to make sure all the electronics are working correctly.
- STEP 2** On the 360 EQUI-FLOW system, the control valve type is Standard Valve. This will need to be specified in the setup of the monitor being used. The **Valve Cal** number should be set to **2123**.
- STEP 3** The flowmeter being used will have a calibration number printed on the tag. The calibration number is 75.5 pulses/gallon. Appropriate conversion factors should be applied depending on the controller being used and the desired output. Most monitors will utilize a **Meter Cal** value of **178**.

NOTE: It is important to weigh the anhydrous ammonia tanks being used to ensure the flowmeter calibration number does not need to be adjusted.

- STEP 4** Make sure the system is discharged of all anhydrous ammonia, and cycle the master and section valves. The control valve should remain in the open position with the system empty.

5-2: METER CAL/VALVE CAL

METER CAL

The 360 EQUI-FLOW flowmeter reads 75.5 pulses per gallon of product. The meter cal conversion number should be based on this number. The calibration number should be checked against known product throughout the system. To do this, apply a tank of anhydrous ammonia and validate the amount of product used to the amount recorded by the rate controller. If amount of product actually weighed out exceeds the amount recorded in the rate controller, adjust the meter calibration number higher. If amount of product actually weighted is less than the amount recorded in the rate controller, adjust the meter calibration number to a lower value. Repeat this process until the amount of applied product is equal to the amount of applied product determined by the rate controller.

Validation of the meter calibration number should be periodically re-checked to ensure optimal metering of anhydrous ammonia through the 360 EQUI-FLOW system.

CONTROL VALVE CAL

The control valve on 360 EQUI-FLOW is referred to in the industry as a "Standard Valve". On most rate controllers, a fast valve calibration number is entered as a 4-digit value. 2123 is a typical calibration number to use for the 360 EQUI-FLOW control valve.

5-3: ORIFICE SELECTION

Use extreme caution and ensure that the 360 EQUI-FLOW system is completely discharged before attempting to change or diagnose orifices.

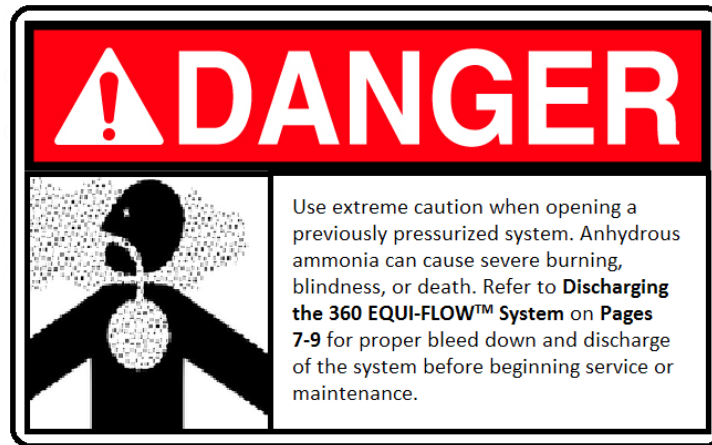

STEP 1 Use the orifice selection guide, page 34, provided to choose the correct orifice for your application.

STEP 2 If only applying one rate at one speed, select the orifice that is the best fit for that specific rate and speed during normal operation.

NOTE: If trying to make an orifice stretch across a few different rate and speed ranges, it may be necessary to look at the opposite ends of the spectrum, and try to select an orifice that will work in all applications.

STEP 3 The pump can be used to slightly increase the operating range of an orifice, but should not be operated out of spec of the recommended operating pressure range to do so.

NOTE: The orifice selection guide should only be used as a baseline. Depending on the setup of the bar and environmental conditions, it may be the case that the recommended orifice is not the right fit for the application.

STEP 4 Once the desired orifices are selected, install them in the orifice bodies at the flow divider with the stamped numbers facing away from the flow dividers, out towards the knives.

STEP 5 Ensure all orifice bodies are re-tightened.

V.

CHAPTER 5 SYSTEM OPERATION (CONTINUED)

5-3: ORIFICE SELECTION (CONTINUED)

WARM TEMPERATURE ORIFICE CHART

Anhydrous Ammonia Orifice charts for 30" Rows from 65 Degrees Fahrenheit to 95 Degrees Fahrenheit

LBS./ACRE	50	60	70	80	90	100	110	120	130	140	150	160	170	180	190	200	210	220	230	240	250	
S	49	49	49	49	49	54	59	59	59	65	70	70	70	78	78	78	86	86	86	86	86	86
P	49	49	49	49	54	59	59	59	70	70	70	78	78	78	86	86	86	86	86	86	86	86
E	49	49	54	54	59	59	65	70	70	78	78	78	86	86	86	86	86	86	86	86	86	86
D	49	54	59	59	59	65	70	70	78	78	78	86	86	86	86	86	86	86	86	86	86	86
M	54	59	59	65	70	70	78	78	86	86	86	86	86	86	86	86	86	86	86	86	86	86
P	59	59	65	70	73	73	78	83	86	86	86	86	86	86	86	86	86	86	86	86	86	86
H	59	65	70	70	78	78	83	86	89	95	95	103	103	103	103	103	103	103	103	103	103	103
	65	70	73	78	78	83	86	89	95	103	103	103	103	103	103	103	103	103	103	103	103	103

ORIFICE SIZE

COLD TEMPERATURE ORIFICE CHART

Anhydrous Ammonia Orifice Charts for 30" Rows from 20 Degrees Fahrenheit to 65 Degrees Fahrenheit

LBS./ACRE	50	60	70	80	90	100	110	120	130	140	150	160	170	180	190	200	210	220	230	240	250	
S	49	49	49	54	54	59	65	65	70	70	70	78	78	78	86	86	89	89	89	89	89	89
P	49	49	54	54	65	65	70	70	78	83	86	86	89	89	89	89	89	89	89	89	89	89
E	49	54	54	65	65	70	70	78	86	86	86	86	86	86	86	86	86	86	86	86	86	86
E	54	54	65	65	70	70	78	83	86	86	86	86	86	86	86	86	86	86	86	86	86	86
D	54	65	65	70	70	78	83	83	86	86	86	86	86	86	86	86	86	86	86	86	86	86
M	65	65	70	70	78	83	83	83	86	86	86	86	86	86	86	86	86	86	86	86	86	86
P	65	70	70	83	83	83	83	83	83	83	83	83	83	83	83	83	83	83	83	83	83	83
H	70	70	83	83	83	83	83	83	83	83	83	83	83	83	83	83	83	83	83	83	83	83
	70	78	83	83	83	83	83	83	83	83	83	83	83	83	83	83	83	83	83	83	83	83

ORIFICE SIZE



CHAPTER 5 SYSTEM OPERATION (CONTINUED)

5-4: CHARGING THE SYSTEM

STEP 1 After ensuring the electronics on the system are working properly, the correct orifices are installed, and all bleeders on the system are closed, make sure everyone is in a safe position.

STEP 2 With the master valve closed and using proper PPE approved for anhydrous ammonia use, slowly open the tank valve, watching for leaks while doing so.

NOTE: If a leak is present, immediately close the tank valve and retreat to a safe position. Do not return until the danger is no longer present.

STEP 3 If any leaks are present, refer to proper bleed down and discharge procedure on pages 7-9 before attempting to diagnose the system.

STEP 4 After any leaks are diagnosed and bleeders closed, make sure the bar is in a safe position to apply anhydrous, and open the master valve to supply anhydrous ammonia to the system and charge the bar. When there is anhydrous coming out of each knife line, the system is charged.

5-5: PUMP OPERATION

Once the system is charged with anhydrous ammonia, it is time to set the pump on the system.

STEP 1 The first step when setting the pump is to check the pressure in the anhydrous ammonia tank. The pressure coming out of the pump should be between **10 and 50 psi above tank pressure**, depending on the outside temperature, and the accuracy of the orifice chosen.

STEP 2 It may be necessary to increase or decrease hydraulic flow to hit rate, as long as the pressure in the system is above tank pressure and not above 160 psi.

STEP 3 Make sure the hydraulic SCV is set in the continuous position, and either push or pull the hydraulic lever depending on the setup of the hydraulic hoses running to the pump.

NOTE: The pump will only run with the master valve on the system in the on position.

STEP 4 Start with the hydraulic flow to the system at a low number. If the flow is too high, the pump could become vapor locked or the increase in pressure could cause the pop-off valve on the manifold to open and release liquid anhydrous ammonia.

STEP 5 Using tank pressure as a baseline, slowly increase the hydraulic flow to the pump to achieve the correct system operating pressure, **10-50 psi above tank pressure**.

STEP 6 As tank pressure increases or decreases throughout the day and season, it may be necessary to adjust the hydraulic flow to compensate.



CHAPTER 5 SYSTEM OPERATION (CONTINUED)

5-5: NORMAL OPERATION PROCEDURE

- STEP 1** When the pump is set to the correct pressure, and the orifices are sized correctly, the system is operated similarly to non-pump anhydrous ammonia systems.
- STEP 2** When you are ready to start applying anhydrous ammonia, make sure hydraulic flow is being supplied to the pump at the correct flow rate, then turn the master valve on to start accurately applying anhydrous ammonia.
- STEP 3** If you should encounter any operational challenges, please see the Troubleshooting section of this manual for guidance (Page 40).

CHAPTER 6 SERVICE AND MAINTENANCE

DANGER

The 360 EQUI-FLOW system must be bled down before any service or maintenance of the system is begun. This includes all service to applicator knives, supply lines, and strainers in addition to the 360 EQUI-FLOW base unit. Refer to pages 7-9 for proper bleed down and discharge procedure.

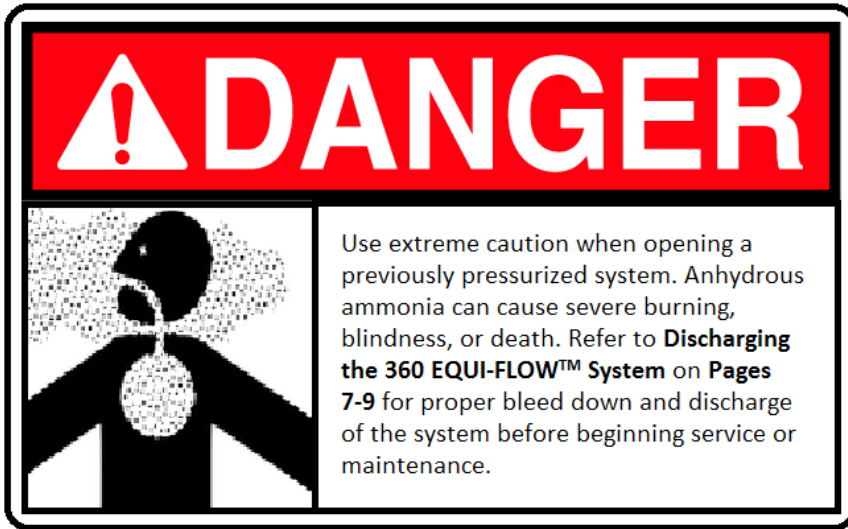

! DANGER

Use extreme caution when opening a previously pressurized system. Anhydrous ammonia can cause severe burning, blindness, or death. Refer to **Discharging the 360 EQUI-FLOW™ System** on Pages **7-9** for proper bleed down and discharge of the system before beginning service or maintenance.

CHAPTER 6 SERVICE AND MAINTENANCE (CONTINUED)

6-1: FILTER MAINTENANCE

STEP 1: REMOVE FILTER TOWER LID

FIGURE 38

STEP 1A Remove the 9 lid bolts with 1-1/8" wrench or socket.

STEP 1B Carefully remove the filter lid by lifting straight up.

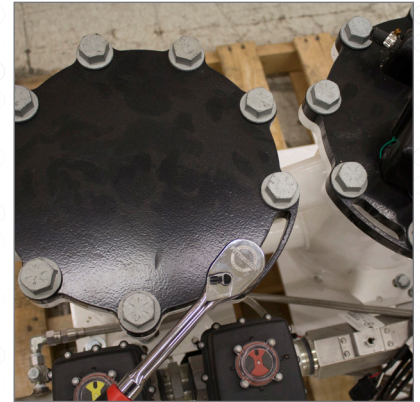

FIGURE 38

STEP 2: REMOVE BASKET STRAINER

FIGURE 39

STEP 2A Remove basket strainer by lifting straight up.

FIGURE 40

STEP 2B Clean magnets attached to lid and basket strainer with compressed air or clean water.

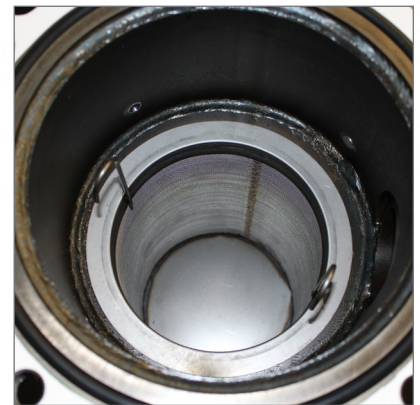

FIGURE 39

STEP 3: REASSEMBLE FILTER TOWER

STEP 3A Reinstall basket strainer.

STEP 3B Inspect tower seal O-Ring (472251) for wear, replace if necessary. Ensure that O-Ring and seat are clear of debris. Lubricate O-Ring with lithium grease and reinstall.

STEP 3C Reinstall tower lid.

STEP 3D Install and torque the 9 lid bolts to 150ft/lbs.



FIGURE 40

CHAPTER 6

SERVICE AND MAINTENANCE (CONTINUED)

6-2: STORAGE

Ensure that the 360 EQUI-FLOW System is completely bled down before opening up the base unit. Refer to Pages 7-9 for proper bleed down and discharge procedure.

STEP 1: REMOVE TOWER LIDS

FIGURE 41

STEP 1A Remove the 18 lid bolts with 1-1/8" wrench or socket.

STEP 1B Carefully remove the tower lids by lifting straight up.

STEP 2: PREP INNER TOWER SURFACES

FIGURE 42

STEP 2A Lightly coat inner tower surfaces with penetrating oil or similar lubricating oil to prevent rust build-up during out of season storage.

STEP 2B Inspect tower seal O-Rings (472251) for wear, replace if necessary. Ensure that O-Rings and seats are clear of debris. Lubricate O-Rings with lithium grease and reinstall.

STEP 2C Reinstall tower lids.

STEP 2D Install and torque the 18 lid bolts to 150ft/lbs.

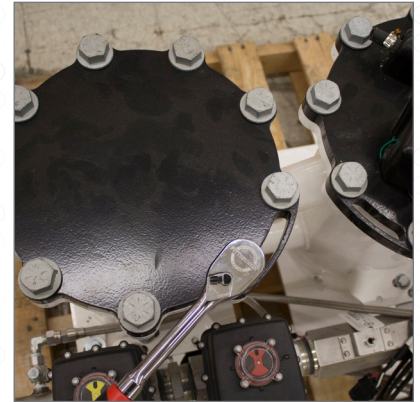

FIGURE 41

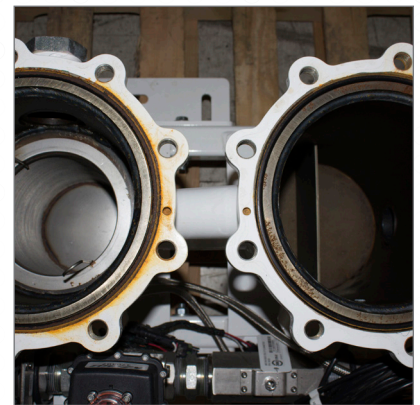

FIGURE 42

VII.

CHAPTER 7
TROUBLESHOOTING

CHALLENGE	SOLUTIONS
Application rate on controller is showing a rate that is higher than the target rate.	<ul style="list-style-type: none"> + If the pressure after the pump [P1] on the system is within the standard operating range of 15 to 40 PSI above tank pressure, the current orifice size could be too large for the current application. + First, try to decrease the hydraulic flow to the pump, while maintaining normal operating pressures. Normal operating pressures should be higher than nurse tank pressure to ensure the NH₃ remains in a liquid form. + If decreasing the hydraulic flow to the pump does not remedy the problem, it may be necessary to reference the orifice chart (Page 34) and choose a smaller orifice.
Application rate on controller is showing a rate that is too low.	<ul style="list-style-type: none"> + Check pump pressure and increase to hit rate. If pressure out of pump is too high, and increasing the hydraulic flow has no effect on rate, it may be necessary to choose a larger orifice. + The next possible cause of this situation could be a plugged strainer. This could be the basket strainer in the filter tower or a Y- Strainer. + It will be necessary to bleed the system to check these screens. Please refer to Pages 7-9 in the manual for the correct bleeding procedure, and always use caution when opening components on a pressurized NH₃ system.

CONTINUED ON NEXT PAGE...

CHALLENGE	SOLUTIONS
Rate Fluctuations	<ul style="list-style-type: none"> + The most common cause of rate fluctuations is an empty NH₃ tank. Check that the tank has a sufficient volume to supply the pump on the system. + The next possible cause of this situation could be the scenario that a screen is plugged, this could either mean the large screen in the filter tower on the system, or a section strainer if equipped. + It will be necessary to bleed the system to check these screens, please refer to Pages 7-9 in the manual for the correct bleeding procedure, and always use caution when opening components on a pressurized NH₃ system. + Check that the pump is on and operating correctly. + Re-check all calibration numbers in the monitor. Incorrect valve calibration numbers can cause the control valve to open and close erratically.
Gauge pressure out of pump too high [P1]	<ul style="list-style-type: none"> + First, try to decrease the hydraulic flow to the pump, while maintaining normal operating pressures. Normal operating pressures should be higher than nurse tank pressure to ensure the NH₃ remains in a liquid form. + If system is equipped with section strainers, it is possible for these to plug before the screen in the filter tower on the system. If section strainers are not plugged, the system may require larger orifices. + It will be necessary to bleed the system to check these screens, please refer to Pages 7-9 in the manual for the correct bleeding procedure, and always use caution when opening components on a pressurized NH₃ system.